

PTZ-N2C200M-DE(B)
2 MP Smart Hybrid Light Mini PT Network Camera



- High quality imaging with 2 MP resolution
- Support Human Detection and Auto-tracking Lite
- Smart Hybrid Light: advanced technology with long range
- Hik-Connect cloud service and APP for remote management and views of devices
- Built-in microphone and speaker for real-time audio security
- Built-in memory card slot, support microSD/SDHC/SDXC card, up to 512 GB
- Water and dust resistant IP66

▪ Specification

Camera	
Image Sensor	1/2.9" Progressive Scan CMOS
Max. Resolution	1920 × 1080
Min. Illumination	Color: 0.01 Lux @(F1.2 , AGC ON), B/W: 0 Lux with light
Lens	
Focal Length	2.8 mm, 4 mm
FOV	2.8 mm, horizontal FOV 104.9°, vertical FOV 58.3°, diagonal FOV 123.3° 4 mm, horizontal FOV 81.3°, vertical FOV 43.7°, diagonal FOV 96.9°
Aperture	F2.0
Illuminator	
Supplement Light Type	IR & White Light
Supplement Light Range	White Light Distance: up to 30 m IR Distance: up to 30 m
Smart Supplement Light	Yes
IR Wavelength	850 nm
PTZ	
Movement Range (Pan)	0° to 345°
Movement Range (Tilt)	0° to 80°
Pan Speed	Pan speed: configurable from 4° to 25°/s
Tilt Speed	Tilt speed: configurable from 4° to 20°/s
Video	
Video Compression	H.265, H.264, MJPEG
H.264 Type	Baseline Profile, Main Profile, High Profile
H.265 Type	Main Profile
Main Stream	50 Hz: 25 fps (1920 × 1080, 1280 × 720) 60 Hz: 30 fps (1920 × 1080, 1280 × 720)
Sub-Stream	50 Hz: 25 fps (640 × 480, 640 × 360) 60 Hz: 30 fps (640 × 480, 640 × 360)
Video Bit Rate	32 Kbps to 8 Mbps
Audio	
Audio Compression	G.711/G.722.1/G.726/MP2L2/PCM//AAC-LC
Audio Bit Rate	16 Kbps (G.722.1)/64 Kbps (G.711)/32 to 192 Kbps (MP2L2)/16 Kbps (G.726)/16 to 64 Kbps (AAC-LC)/8 to 48 Kbps (PCM)
Audio Sampling Rate	8 kHz/16 kHz
Environment Noise Filtering	Yes
Network	
Protocols	IPv4/IPv6, HTTP, HTTPS, Qos, DNS, DDNS, NTP, RTSP, RTP, TCP/IP, UDP, DHCP, Bonjour
API	ONVIF (ProfileS, ProfileG, ProfileT), ISAPI, SDK, ISUP
Image	
Image Settings	Saturation, brightness, contrast, and sharpness adjustable by client software or web browser
Wide Dynamic Range (WDR)	Digital WDR
Image Enhancement	BLC, HLC, 3D DNR

Interface	
Ethernet Interface	1 RJ45 10 M/100 M self-adaptive Ethernet port
On-board Storage	Built-in memory card slot, support microSD/SDHC/SDXC card, up to 512 GB
Built-in Microphone	1 built-in speaker
Built-in Speaker	1 built-in speaker
Reset	Yes
Event	
Basic Event	Motion detection (support alarm triggering by specified target type (human)), video tampering alarm, exception
Alarm Linkage	Upload to FTP/memory card, notify surveillance center, send email, trigger capture, audible warning, auto-tracking lite
General	
Operating Condition	-10 °C to 40 °C (-14 °F to 104 °F). Humidity 90% or less (non-condensing)
General Function	Mirror, password protection, watermark
Power	12 VDC ± 25%, 0.75 A, max. 9 W, Ø5.5 mm coaxial power plug, reverse polarity protection, PoE: IEEE 802.3af, 36 V to 57 V, 0.2 A to 0.3 A, max. 10.5 W
Dimensions	Camera dimension: 163.9 mm × 185.8 mm × 131.9 mm (6.45" × 7.31" × 5.19") With package dimension: 224 mm × 164 mm × 230 mm (8.82" × 6.46" × 9.06")
Weight	Camera weight: 600 g (1.32 lb.) With package weight: 900 g (2.0 lb.)
Approval	
EMC	CE-EMC (EN 55032:2015, EN 61000-3-2:2019, EN 61000-3-3:2013 + A1:2019, EN 50130-4:2011 + A1:2014)
Protection	IP66 (IEC 60529-2013)

▪ Typical Application

Hikvision products are classified into three levels according to their anti-corrosion performance. Refer to the following description to choose for your using environment.

This model has NO SPECIFIC PROTECTION.

Level	Description
Top-level protection	Hikvision products at this level are equipped for use in areas where professional anti-corrosion protection is a must. Typical application scenarios include coastlines, docks, chemical plants, and more.
Moderate protection	Hikvision products at this level are equipped for use in areas with moderate anti-corrosion demands. Typical application scenarios include coastal areas about 2 kilometers (1.24 miles) away from coastlines, as well as areas affected by acid rain.
No specific protection	Hikvision products at this level are equipped for use in areas where no specific anti-corrosion protection is needed.

▪ Available Model

PTZ-N2C200M-DE(2.8mm)(B)

PTZ-N2C200M-DE(4mm)(B)

▪ Dimension

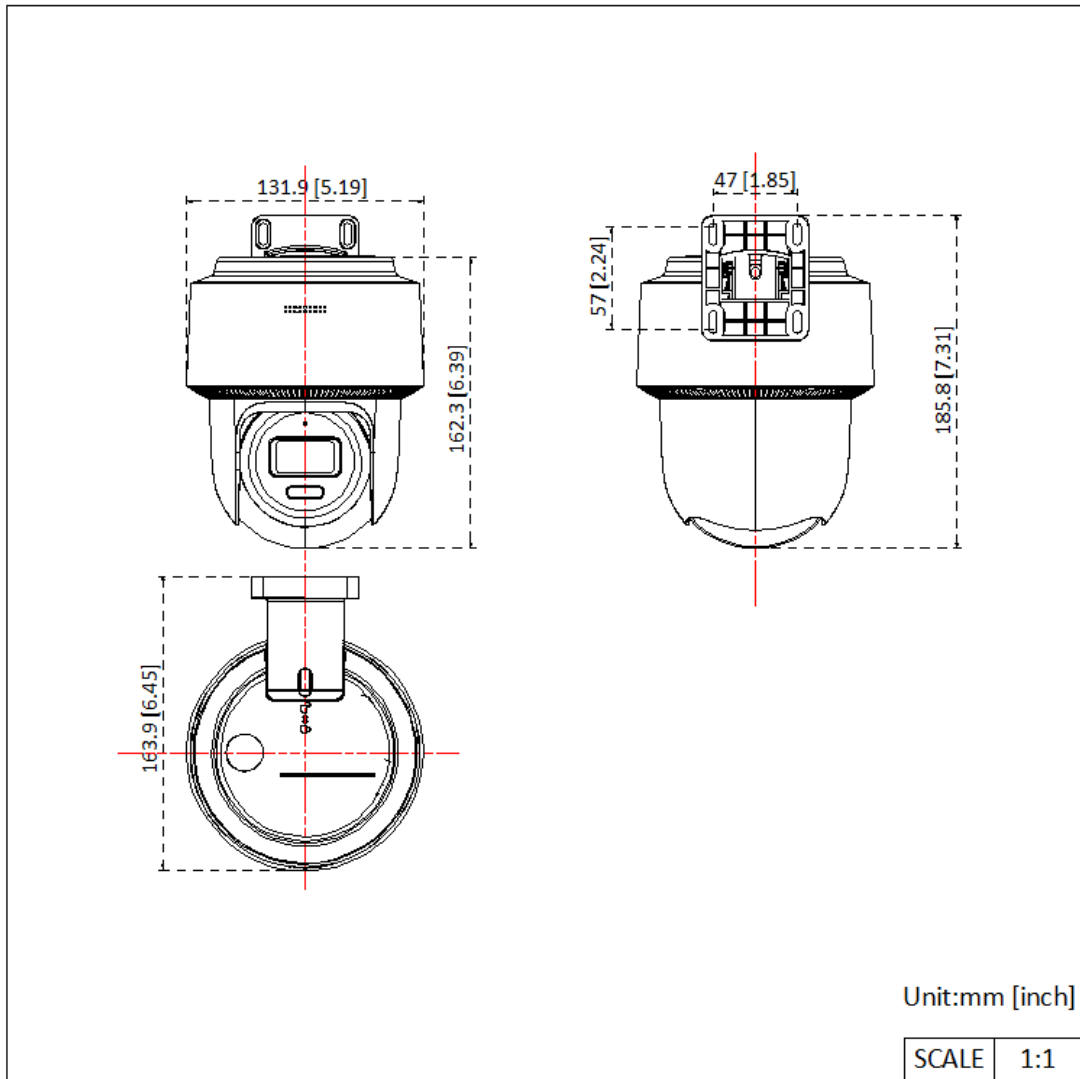

See Far, Go Further



www.hikvision.com
support@hikvision.com



© Hangzhou Hikvision Digital Technology Co., Ltd. Unless otherwise agreed, Hikvision makes no warranties, express or implied. We reserve the right to introduce modifications without notice.

HiLook